



RESOURCE ENGINEECH (INDIA) PVT LTD.
 BARODA - 390010, INDIA.
 E MAIL :- into@resource.co.in.
 FAX NO:- +91-265-2638048

CUSTOMER NAME :-

DATA SHEET NO:- 5

ALL DIMENSION
 IN MM

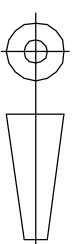

SCALE
 N.T.S.

3" QUICK LOCK

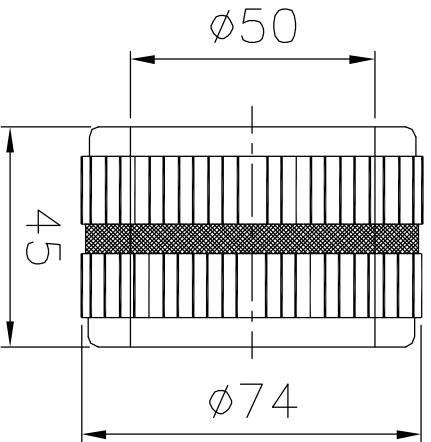

3" QUICK LOCK

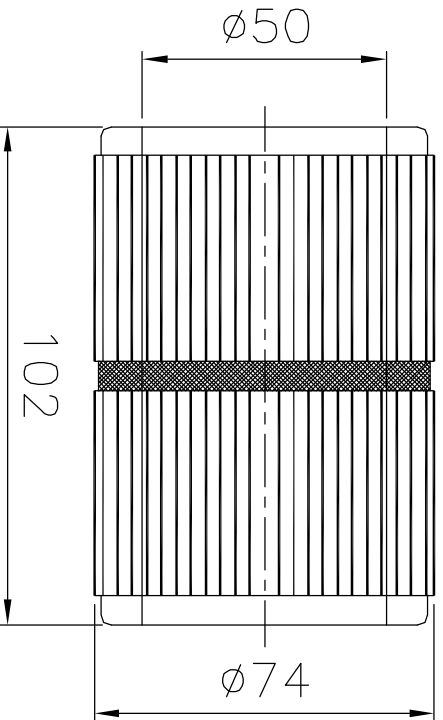

COLLAPSAD:- 74
 EXPANDED:- 78
 MIN BORE:- 38
 MAX BORE:- 50

6" QUICK LOCK

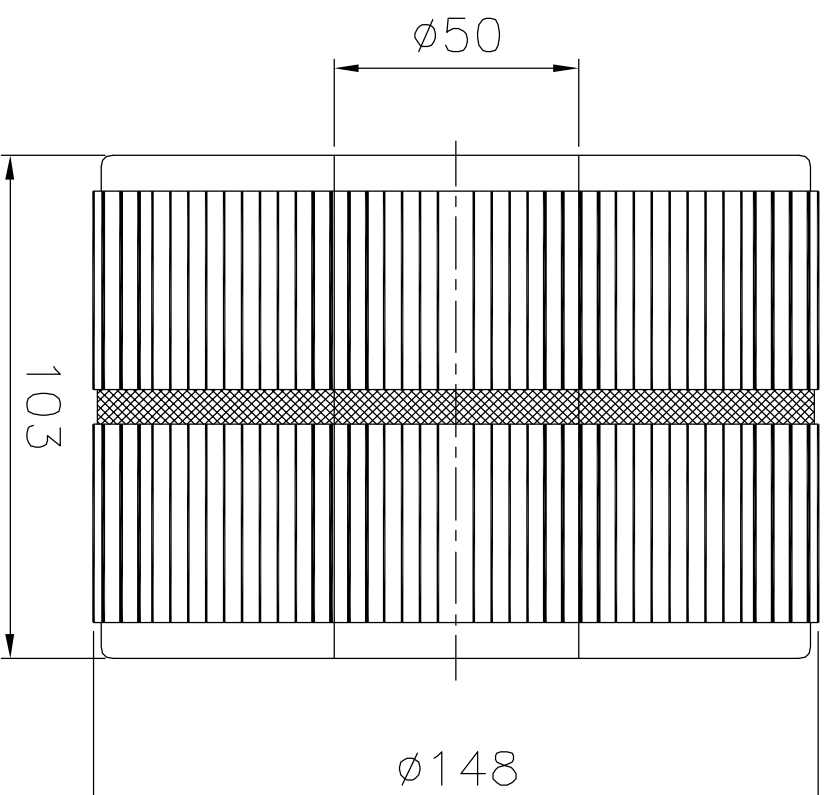
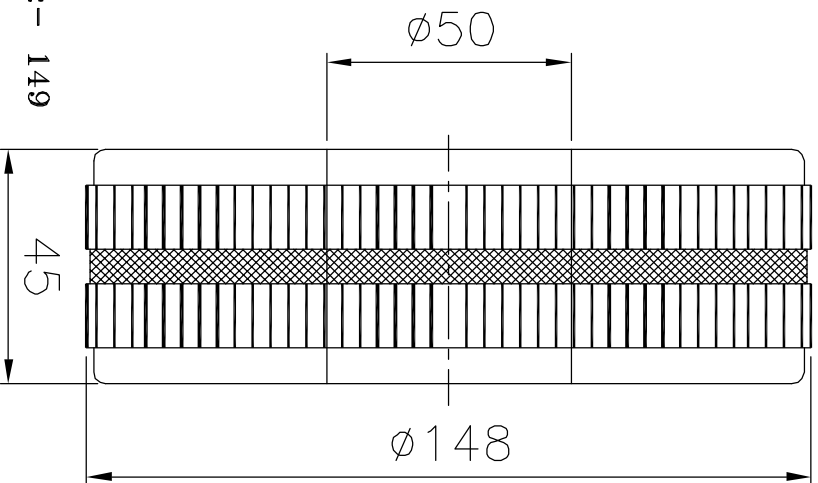

COLLAPSAD:- 149
 EXPANDED:- 154
 MIN BORE:- 45
 MAX BORE:- 50

BASIC CUSTOMER FEEDBACK

PRESENT GRIPPING WIDTH:-	CORE INNER DIAMETER:-
MACHINE NAME:-	COLLAPSED SHAFT DIAMETER:-
MAX GRIPPING WIDTH:-	EXPANDED SHAFT DIAMETER:-
MIN GRIPPING WIDTH:-	SPEED :-
LOAD :-	CORE MATERIAL :-

FOR IMPROVEMENT & MODIFICATION RESOURCE HAS RIGHT TO CHANGE DIMENSION WITHOUT PRIOR NOTICE.